

**THE AQUARIUS CONSTRUCTION TASK II**  
**(ACT II)**  
**Learning Without Boundaries**  
A Distance Learning Outpost Educational Challenge  
Johnson Space Center

Materials

In making your model it is best to use readily available materials. They should be simple to work with and easily joined together. Several possible sets of materials are:

<b>Option #1</b>	<b>Option #2</b>	<b>Option #3</b>	<b>Option #4</b>
Drinking straws Paper clips	Drinking straws Clay	Newspaper Tape	Craft sticks Clay

Background

The objective is to simulate the communication skills and construction techniques that are needed by the sixteen participating countries as they work together to build the International Space Station.

Just how difficult is it to translate ideas, words, and pictures into a 3-dimensional structure? Come along with us to explore the Aquarius Construction Task II. In the end you will have a better understanding of the creativity and the engineering challenges required to build the International Space Station and an opportunity to talk with some of the people training to meet that challenge!

This is a great opportunity for young people to apply real-life science and math using their creative, uninhibited minds to work in teams toward a common goal.

Procedure

**CONSTRUCTION CHALLENGE**

Using a chosen set of materials (straws-paperclips, straws-clay, craft sticks-clay **or** newspaper and tape) build the structure that is illustrated in figure 9.

Notes to the teacher:

Try to provide some time to practice building with these materials (straws-paperclips straws-clay, or craft sticks-clay) to allow the students to become familiar and comfortable with the task. Use figures 1, 2, 3, 4, and 5 as a guide.

In a similar way, if you choose to use the rolled paper and tape, allow the students to practice building with these materials before the actual task. Use figures 6 and 7 as a guide.

Once student teams have had some time to practice with the material, provide Figures 8 and 9 as a reference.

Each team is to make one rectangular cube and attach three of the six connecting pieces that will hold the two rectangular cubes together.

### **OPTION #1 BUILDING STRUCTURES WITH PAPER CLIPS AND STRAWS**

To make the right angles to build a cube of straws follow these directions.

1. Push the side of the paperclip with two heads into the straw.
2. Slide another paperclip onto the first one (fig. 2).
3. Slide a second straw onto the dangling paperclip. Now you have created a right angle (fig. 3).
4. Repeat this procedure to form a rectangle.
5. Build a second rectangle.
6. At each of the corners on both rectangles slide a third paperclip onto each corners.
7. Slide a straw onto the third paperclip to form a rectangular cube.
8. Build two rectangular cubes (fig. 8). The middle supports can be attached with paperclips and straws as illustrated in Figure 4.

### **OPTION #2 BUILDING STRUCTURES WITH PLASTIC STRAWS**

Straws can be joined together in many different ways. For example, using bits of clay, or tapping them together or by squeezing one end of a straw and placing it inside another to build a longer section of your structure (fig.1). These extended straws will be used for the longer sides of the rectangular cube that will be constructed (fig. 8 and 9) by each team. See directions above.

### **MAKING A STRAW RECTANGULAR CUBE STAND BY ITSELF**

These rectangular cubes will not stand by themselves very well. Therefore you will need to attach additional supports that will form a triangle at each corner (fig. 5).

An extension question to ask is, "What would be the minimum number of straws you would need to add to make the cube stand by itself?"

After practicing your construction techniques for a short period of time go ahead and build two rectangular cubes, each with three connecting pieces. Use the illustrations shown in figures 8 and 9 as your guide. **Remember** to come to an agreement with the other team on the size and dimensions of the rectangular cubes!

You can use any combination of materials for your construction. See directions above in Option #1. Straws and clay, Straws and paperclips, Craft sticks and clay.

### **OPTION #3 BUILDING STRUCTURES WITH NEWSPAPER**

Full sized sheets of newspaper can be tightly rolled and taped to make stiff tubes of paper for your freestanding structure.

1. Tightly roll the newspaper into several long tubes (fig. 6).
2. Secure the tube with a minimum amount of tape (clear or masking).
3. Attach two or more tubes together to make the longer sides of the rectangular cube. Single tubes will be used for the cross pieces and the connector pieces.
4. There are several ways to attach one paper tube to another at the joints. One way is to use tape at the joints. Another stronger way is to wrap some extra newspaper around the joined ends of the tubes and then secure them with tape. You are making a paper sleeve to wrap around the joined ends.
5. Your completed rectangular cube should look similar to figure 7.
6. You will need to determine where three of the six connector pieces will be attached to your cube and then tape them to your cube.

After practicing your construction techniques for a short period of time go ahead and build a rectangular cube with three connecting pieces. Use the illustrations shown in figures 8 and 9 as your guide. **Remember** to come to an agreement with the other team on the size and dimensions of the rectangular cubes!

## COMMUNICATION CHALLENGE

To experience the skills needed to understand ideas, directions, and actions that are experienced by NASA's astronauts while building the International Space Station.

Student teams must communicate and agree between themselves on the following points:

1. The units of measure to be used,
2. The size and dimensions of the rectangular cubes,
3. The location of the six connecting pieces,
4. How long the connecting pieces will be,
5. Which three connectors each team will make,
6. At what location will all six connectors be placed,
7. Each team then builds its half of the structure, consisting of one completed rectangular cube and three connectors,
8. When each team is finished, they meet together to see if their two halves will fit together as planned and communicated.

Notes to the teacher:

To add more realism to the Challenge separate the two teams by distance or a barrier that will prohibit the teams from seeing each other during their construction activities.

Do not allow the teams to communicate directly to each other but only through written notes.

Each team then builds one rectangular cube to the agreed upon size and dimensions.

After the rectangular cubes have been completed the teams must communicate and agree on the length and location of the six connecting pieces that will be used to hold the two rectangular cubes together.

## COMING TOGETHER FOR THE TEST FIT

Each team, after completion of their  $\frac{1}{2}$  of the structure, will meet together for the first time to test fit their  $\frac{1}{2}$  to each other's.

How well did they fit together?

## DEBRIEFING THE ACTIVITY

What were the:

- ❖ Successes and failures of the team.
- ❖ Problems and solutions found in building your structure.
- ❖ Most confusing or understandable parts of communicating.

## UNDER THE SEA WITH NEEMO AT AQUARIUS

The astronauts and aquanauts are doing a very similar activity under the water at the Aquarius research station.

1. What have you found out during your activity that would help make their construction-communication task easier?
2. How would these practice-learning activities underwater help NASA's astronauts in space while they are constructing the International Space Station?
3. Just how difficult is it to translate ideas, words, and pictures into a 3-dimensional structure?

Now you can imagine the creativity and the engineering wonder that the International Space Station requires as we take this next bold step in our exploration of Space.

## Presentation

1. As part of the event, please prepare 1-2 student representatives to share information about the group's construction activity. The students will be expected to say their names and provide the following information about their structures within 3-5 minutes:
  - a. Successes & failures of the team
  - b. Problems & solutions found in building your structure.
  - c. Most confusing or understandable parts of communicating.
2. You will receive a script (voice protocol) via e-mail no later than 2 business days prior to your event. This document will help you know when you students will be called on to present during & ask questions the event.
3. **MOST IMPORTANTLY!!!! ENJOY YOUR VISIT WITH THE ASTRONAUTS AND AQUANAUTS ABOARD THE AQUARIUS RESEARCH STATION. SHARE AND LEARN TOGETHER!**

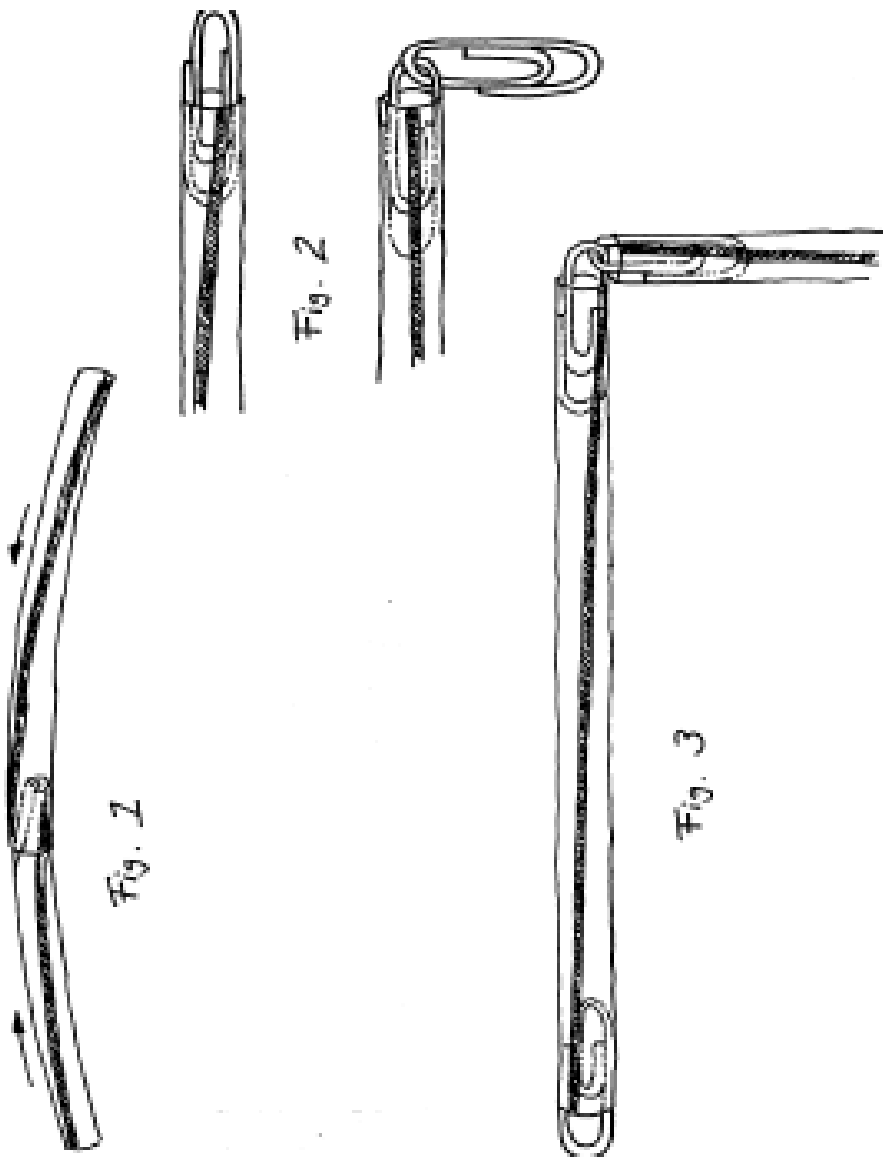

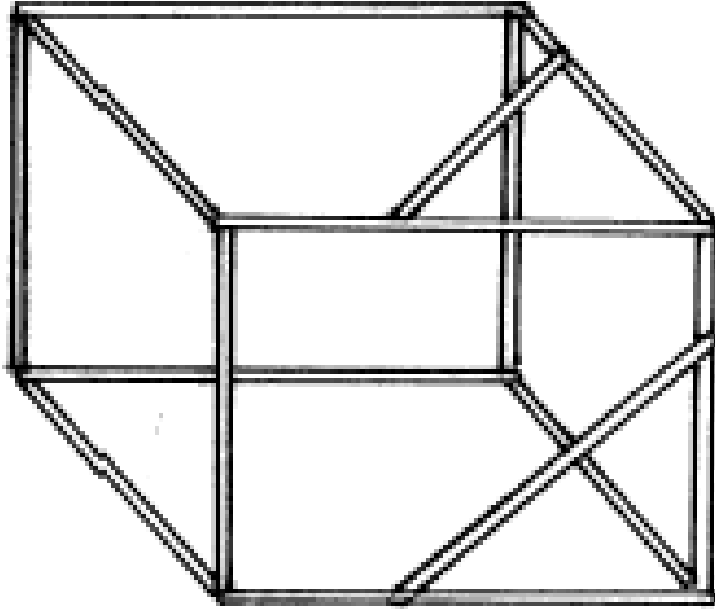

Fig. 5

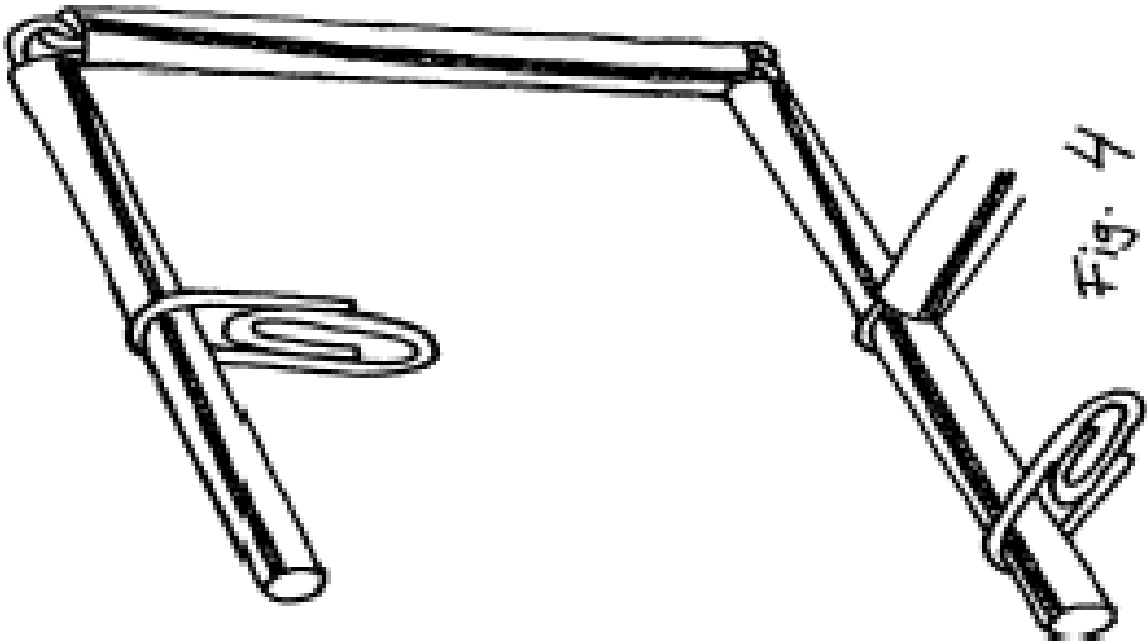
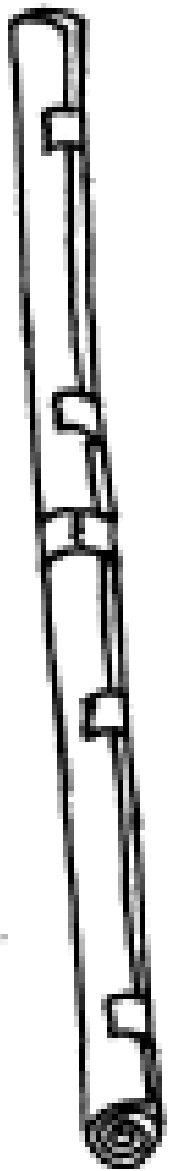
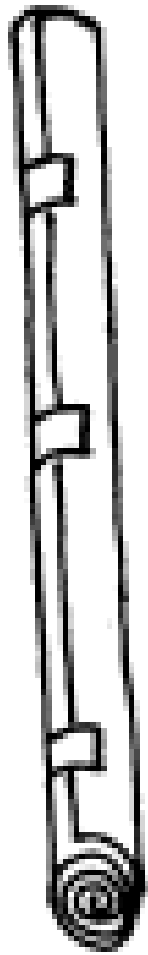

Fig. 4



Fig. 6



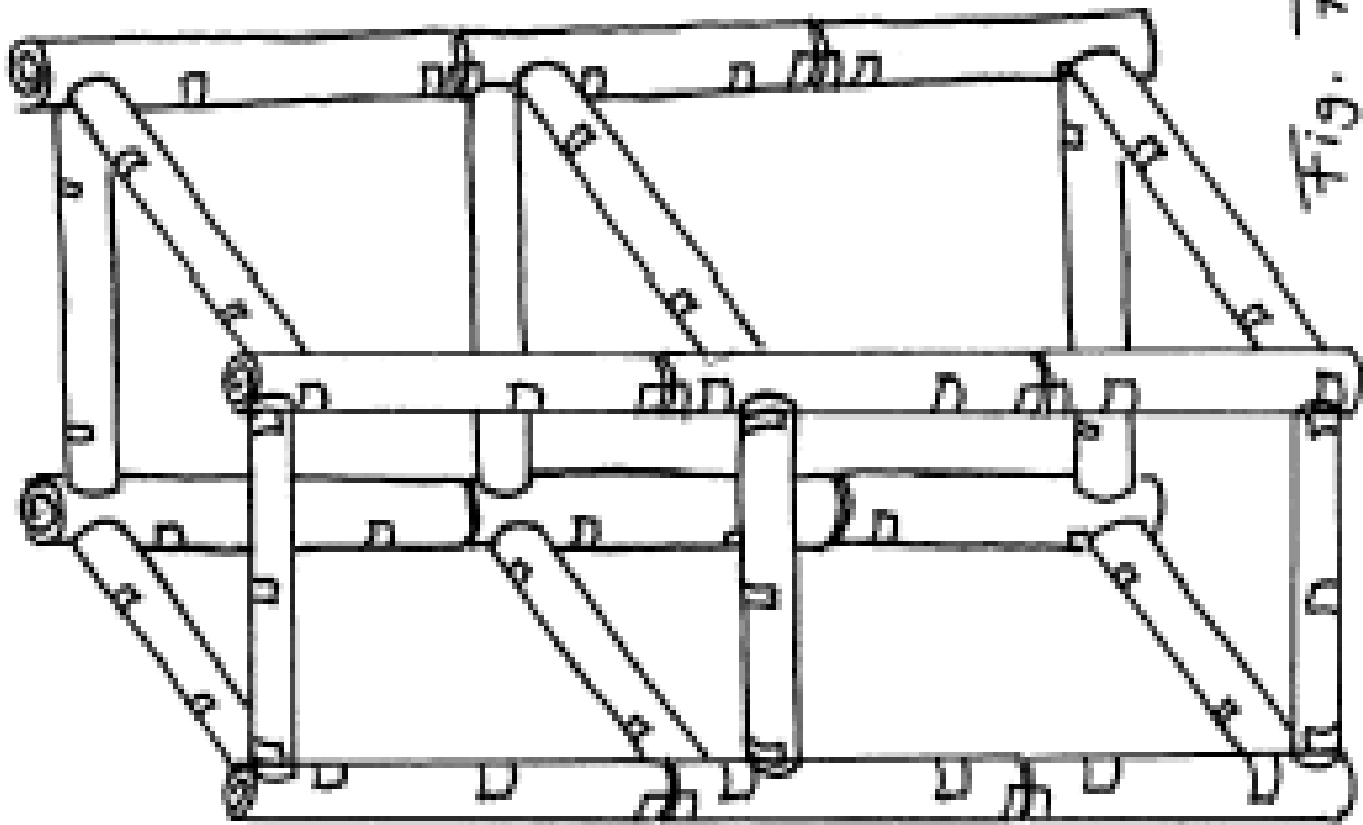

Fig. 7

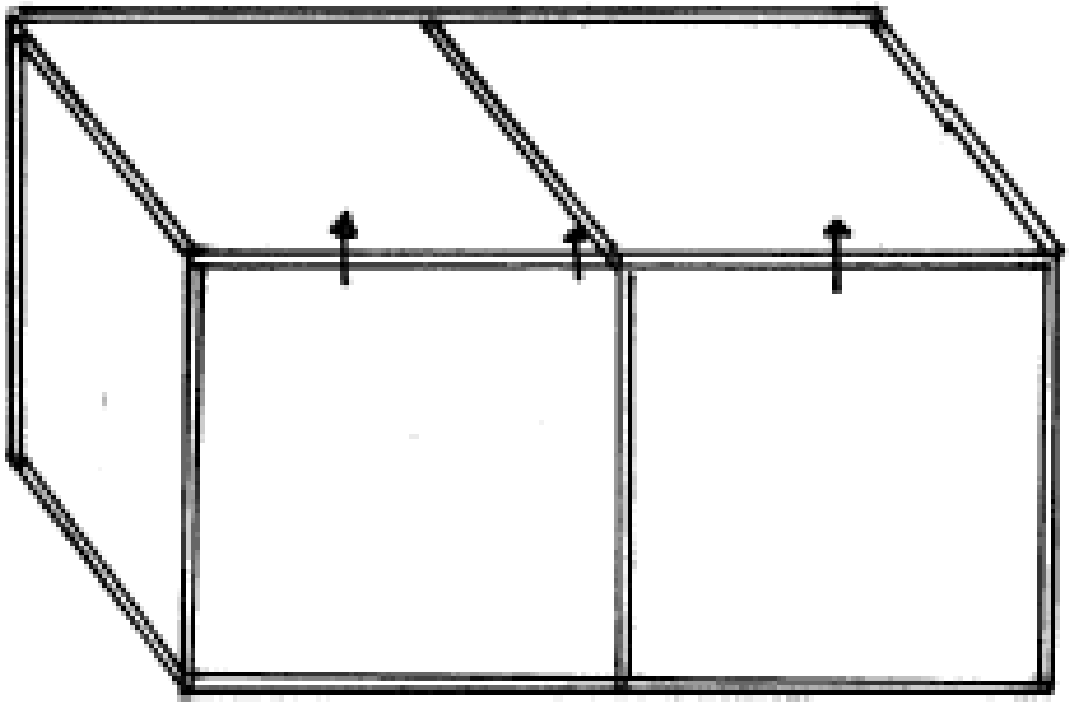
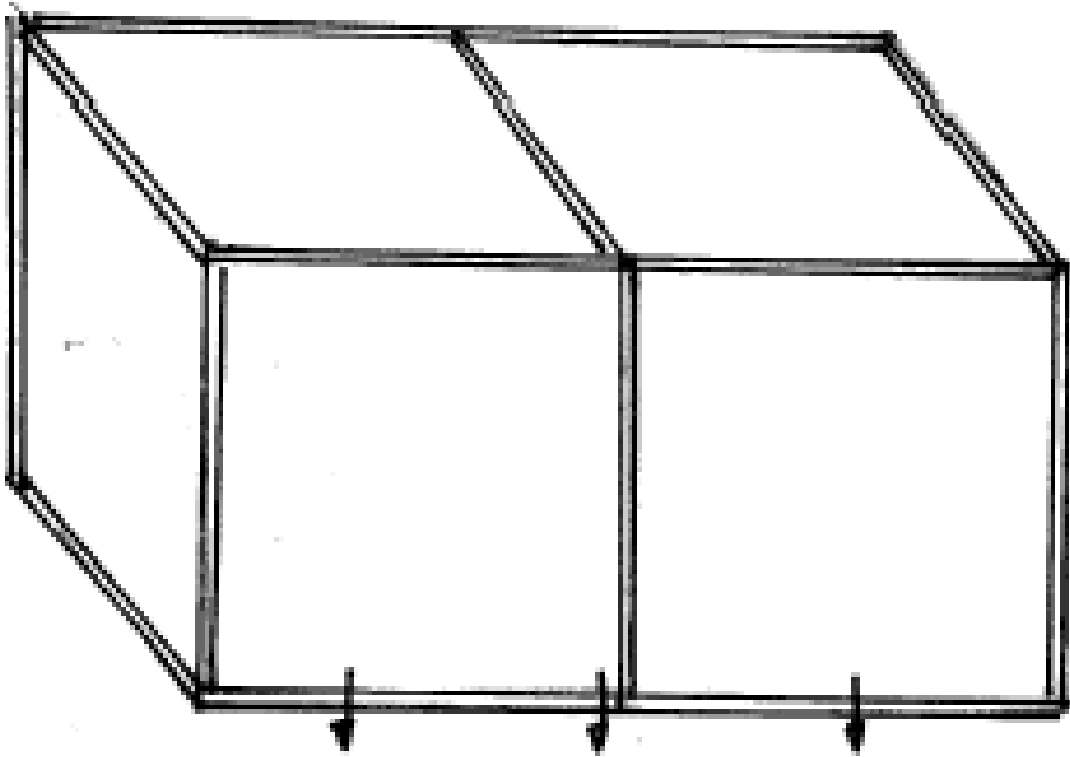
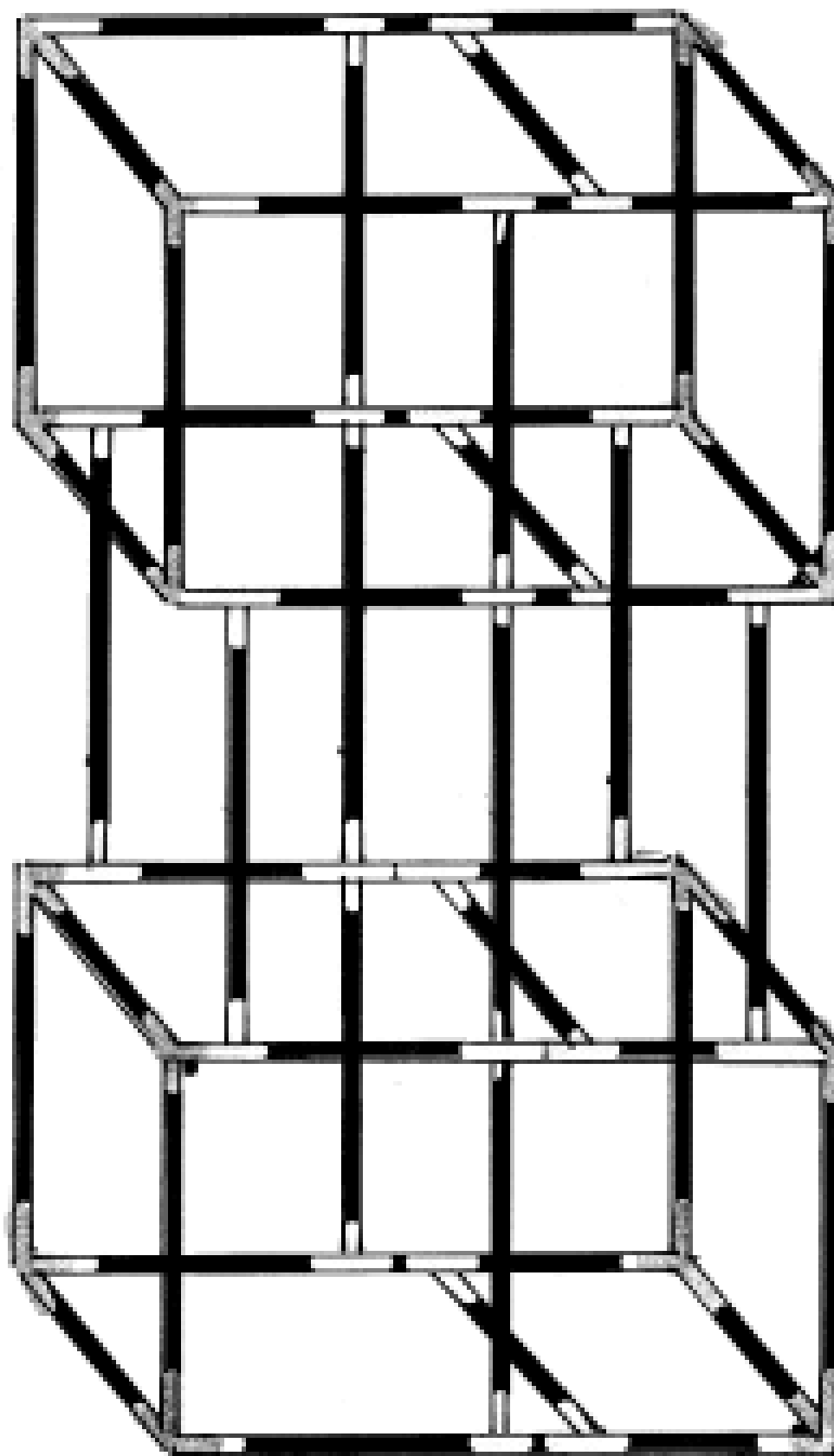

Fig. 8



*Fig. 9*  
**Waterlab Connection Schematic  
Center**